

2021 PRICE SHEET FOR CATCH BASINS

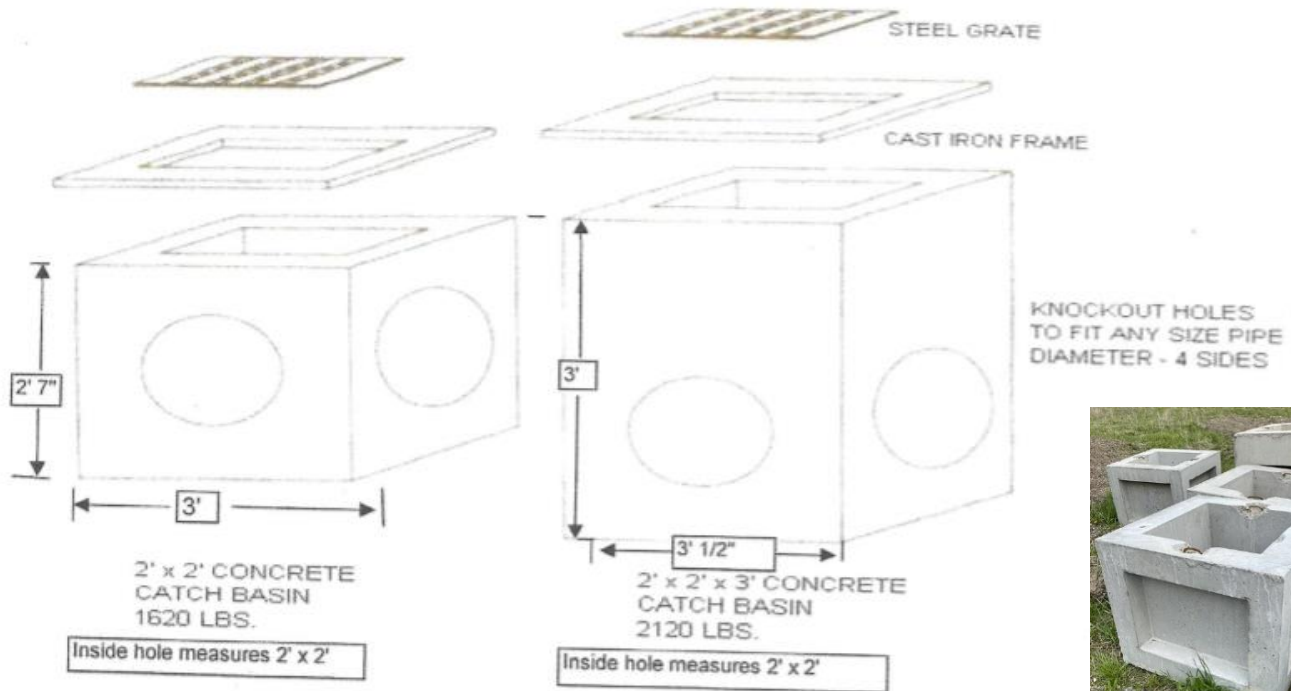

Custom Mix Concrete, Inc.
Your Full Service Concrete Supplier



USED FOR STORM DRAINAGE APPLICATIONS, 2' x 2' OUTSIDE DIAMETER, 6" CONCRETE WALLS, 3500 PSI CONCRETE WITH REINFORCED BARS.

DIMENSIONS:

2' x 2' x 2' CONCRETE CATCH BASINS
INCLUDES STEEL FRAME & GRATE
CATCH BASIN ONLY
FRAME & GRATE ONLY

2' x 2' x 3' CONCRETE CATCH BASINS
INCLUDES STEEL FRAME & GRATE
CATCH BASIN ONLY
FRAME & GRATE ONLY

CATCH BASIN RISER \$20.00/EA.

SALES TAX AND DELIVERY CHARGE ADDED TO ABOVE COSTS.

*DELIVERY	HOURLY RATE
BOOM TRUCK	\$100.00 /HR.
TRACTOR TRAILER	\$125.00 /HR.

WEIGHT
1,620 LBS.

PRICE
\$625.00/EA.

\$255.00/EA
\$390.00/EA

2,120 LBS.

\$675.00/EA.

\$305.00/EA
\$390.00/EA

CONTACT INFORMATION:

President - John Pipher (607) 481-1222
Sales Representative: Rick Hitchcock (607) 731-9248
Block Shop Manager: Kelly Crane-Donley (607) 769-7833
E-Mail: custommixconcrete@gmail.com

LOCATIONS:

206 W. Water St. Addison, NY 14801 (607) 359-3436
1229 Lowman Road, Lowman, NY 14861 (607) 737-0281

*Delivery Starts at time of load to time truck gets back to our shop.