



Custom Mix Concrete, Inc.
Your Full Service Concrete Supplier



2021 PRECAST CONCRETE PRODUCTS BROCHURE

QUALITY PRODUCTS & SERVICES



HEADWALLS 12", 15", 18", 24" & 36"



SEPTIC TANKS (500, 1000 & 1500 Gallon Dual Chamber)



Ferrario Ford Dealership - Big Flats, NY

RETAINING WALL BLOCKS

Serving Chemung & Steuben Counties in NY & Bradford & Tioga Counties in PA
Residential, Commercial, Industrial & Municipal Customers

- **SEPTIC TANKS & DISTRIBUTION BOXES**
- **RETAINING WALL BLOCKS (DECO & PLAIN FACED)**
- **HEADWALLS**
- **CATCH BASINS**
- **DRYWELL TANKS**
- **FRESH WATER TANKS**



ADDISON CONCRETE PLANT:
206 W. WATER STREET
ADDISON, NY 14801
PHONE: (607) 359-3436
FAX: (607) 359-3652

HOME OFFICE LOCATION:
1229 LOWMAN ROAD
LOWMAN, NY 14861
PHONE: (607) 737-0281
FAX: (607) 737-0349

2021 PRICE SHEET FOR RETAINING WALL BLOCKS



Custom Mix Concrete, Inc.
Your Full Service Concrete Supplier

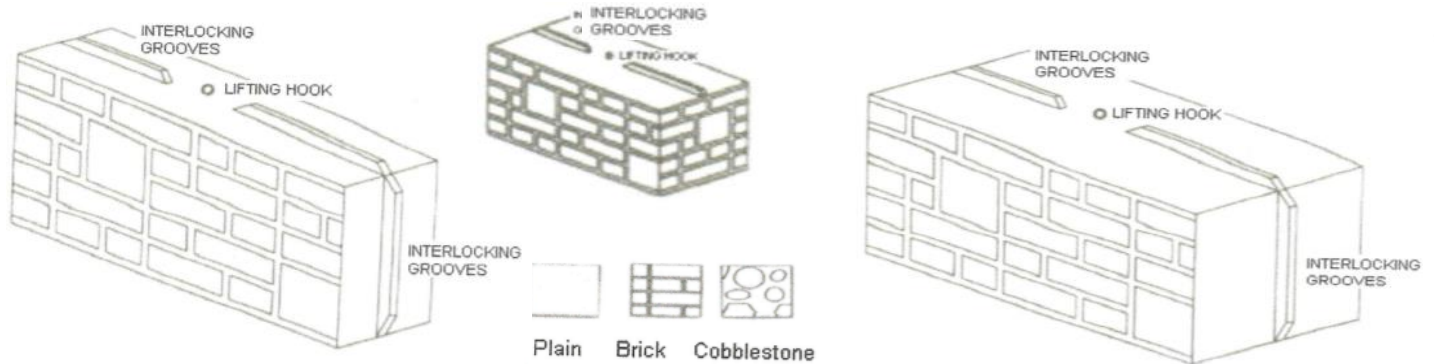

PLAIN FACED:	DIMENSIONS	WEIGHT	*PRICE	DECO FACED END:	DIMENSIONS	WEIGHT	*PRICE
	2' x 2' x 2'	1140 lbs.	\$ 86.00		2' x 2' x 2'	1140 lbs.	\$ 122.00
	2' x 2' x 4'	2280 lbs.	\$ 104.00		2' x 2' x 4'	2280 lbs.	\$ 132.00
	2' x 2' x 6'	3440 lbs.	\$ 128.00		2' x 2' x 6'	3440 lbs.	\$ 156.00
	2' x 2' x 8'	4600 lbs.	\$ 156.00		2' x 2' x 8'	4600 lbs.	\$ 182.00
	14" x 2' x 2'	700 lbs.	\$ 84.00		14" x 2' x 2'	700 lbs.	\$ 119.00
	14" x 2' x 4'	1400 lbs.	\$ 96.00		14" x 2' x 4'	1400 lbs.	\$ 124.00
	14" x 2' x 6'	2000 lbs.	\$ 120.00		14" x 2' x 6'	2000 lbs.	\$ 141.00
	14" x 2' x 8'	2600 lbs.	\$ 146.00		14" x 2' x 8'	2600 lbs.	\$ 164.00
COBBLESTONE	2' x 2' x 2'	1140 lbs.	\$ 91.00	45° ANGLED BLOCKS:			
OR	2' x 2' x 4'	2280 lbs.	\$ 109.00		2' x 2' x 4'	3300 lbs.	\$ 162.00
BRICK FACED:	2' x 2' x 6'	3440 lbs.	\$ 140.00		14" x 2' x 4'	1970 lbs.	\$ 154.00
	2' x 2' x 8'	4600 lbs.	\$ 169.00	22° ANGLED BLOCKS:			
	14" x 2' x 2'	700 lbs.	\$ 89.00		2' x 2' x 4'	2280 lbs.	\$ 129.00
	14" x 2' x 4'	1400 lbs.	\$ 105.00		2' x 2' x 6'	3440 lbs.	\$ 134.00
	14" x 2' x 6'	2000 lbs.	\$ 125.00		2' x 2' x 8'	4600 lbs.	\$ 165.00
	14" x 2' x 8'	2600 lbs.	\$ 151.00				
2' CONCRETE CAPS	2'		\$ 70.00	* Plus applicable Sales Tax (NY 8%, PA 6%)			
	4'		\$ 80.00	** DELIVERY / HAUL RATES:			
	6'		\$ 90.00	BOOM TRUCK	\$100.00/HR.		
	8'		\$ 100.00	TRACTOR TRAILER	\$125.00/HR.		
14" CONCRETE CAPS	2'		\$ 60.00	**Delivery starts at time of load until time truck gets back to shop.			
	4'		\$ 70.00				
	6'		\$ 80.00				
	8'		\$ 90.00				

DBL MALE	2' x 2' x 2'	1140 lbs.	+ \$26.00/Block
DBL FEMALE	2' x 2' x 4'	2280 lbs.	+ \$26.00/Block
END BLOCKS	2' x 2' x 6'	3440 lbs.	+ \$26.00/Block
	2' x 2' x 8'	4600 lbs.	+ \$26.00/Block

SECONDS: (OUR SECONDS ARE BASED ON AVAILABILITY)
2' x 2' x 4' - \$45.00 + TAX, 2' x 2' x 6' - \$55.00 + TAX

CONTACT INFORMATION:

President - John Pipher (607) 481-1222
Sales Representative: Rick Hitchcock (607) 731-9248
Block Shop Manager: Kelly Crane-Donley (607) 769-7833
E-Mail: custommixconcrete@gmail.com

LOCATIONS:

206 W. Water St. Addison, NY 14801 (607) 359-3436
1229 Lowman Road, Lowman, NY 14861 (607) 737-0281

2021 PRICE SHEET FOR SEPTIC TANKS



Custom Mix Concrete, Inc.
Your Full Service Concrete Supplier

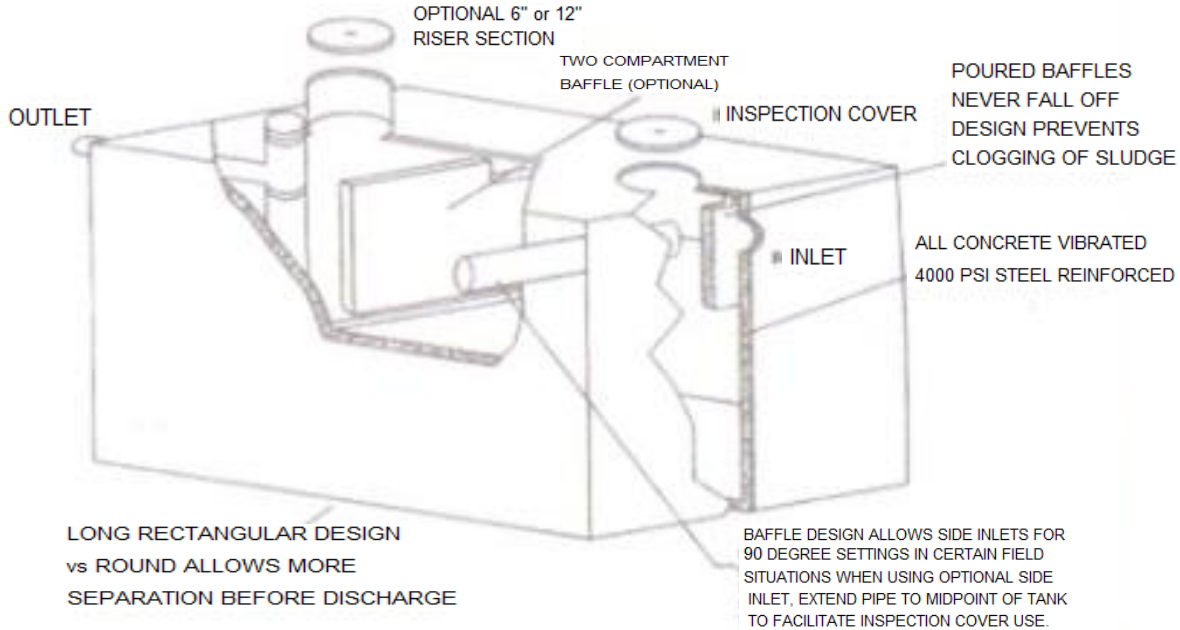

SPECIFICATIONS:

DESCRIPTION	WEIGHT	LENGTH	WIDTH	HEIGHT	CTR OF INLET	CTR OF OUTLET
500 GALLON	5,500 LBS.	68"	53"	60"	52"	49"
1000 GALLON STANDARD	7,724 LBS.	96"	62"	68"	58"	55"
1000 GALLON - DUAL	7,724 LBS.	96"	62"	68"	58"	55"
1000 GALLON - NEW	8,000 LBS.	99"	68"	60"	52"	49"
1500 GALLON - DUAL	12,500 LBS.	147"	68"	60"	52"	49"

PRICES:

HOMEOWNERS

1 - 4 PURCHASED

500 GALLON STANDARD	\$ 750.00 / EACH
1000 GALLON - DUAL	\$ 900.00 / EACH
1500 GALLON - DUAL	\$1,350.00 / EACH

CONTRACTORS AFTER

PURCHASE OF 5 TANKS

\$ 720.00 / EACH
\$ 860.00 / EACH
\$1,300.00 / EACH

DELIVERY CHARGES TO BE ASSESSED SHOULD DISTANCE TO JOBSITE EXCEED TEN (10) MILES. SHOULD ANY JOBSITE CONDITIONS CAUSE DELAYS UPON ARRIVAL, ADDITIONAL CHARGES MAY ALSO APPLY.

ACCESSORIES:

BIO-FILTERS	\$115.00/EA.
INFILTRATORS	\$60.00/EA.
CAPS	\$20.00/EA.
SPEED LEVELERS	\$2.75/EA.
SEPTIC TANK TAPE	\$28.00/ROLL
SEPTIC TANK COVER (REGULAR LID 24" W x 5" H)	\$ 50.00/EA.
SEPTIC TANK COVER (FLAT LID 30" W x 3" H)	\$ 50.00/EA.
6" & 12" RISER EXTENSIONS (22" W)	\$ 50.00/EA.

SHOWN: 30" WIDE SEPTIC TANK COVER WITH 6" HIGH RISER EXTENSION.



CONTACT INFORMATION:

President - John Pipher (607) 481-1222

Sales Representative: Rick Hitchcock (607) 731-9248

Block Shop Manager: Kelly Crane-Donley (607) 769-7833

E-Mail: custommixconcrete@gmail.com

LOCATIONS:

206 W. Water St. Addison, NY 14801 (607) 359-3436

1229 Lowman Road, Lowman, NY 14861 (607) 737-0281

SALES TAX ADDED TO ABOVE COSTS.

2021 PRICE SHEET FOR DISTRIBUTION BOXES



Custom Mix Concrete, Inc.
Your Full Service Concrete Supplier

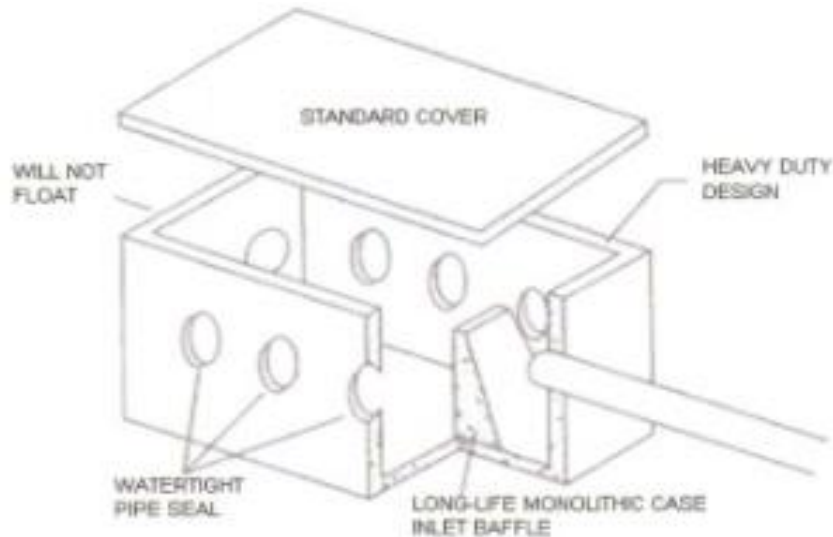

SHOWN: 8 OUTLET DISTRIBUTION BOX

CONCRETE DISTRIBUTION BOXES:

PRICE

*6 OUTLET RAISED MOUND DISTRIBUTION BOX	\$ 120.00/EA.
6 OUTLET STANDARD DISTRIBUTION BOX	\$ 120.00/EA.

*THE HOLES SIT LOWER ON BOX - PAINTED ORANGE IN YARD.

ACCESSORIES:

BIO-FILTERS	\$115.00/EA.
INFILTRATORS	\$60.00/EA.
CAPS	\$20.00/EA.
SPEED LEVELERS	\$2.75/EA.
SEPTIC TANK TAPE	\$28.00/ROLL

CONTACT INFORMATION:

President - John Pipher (607) 481-1222
Sales Representative: Rick Hitchcock (607) 731-9248
Block Shop Manager: Kelly Crane-Donley (607) 769-7833
E-Mail: custommixconcrete@gmail.com

LOCATIONS:

206 W. Water St. Addison, NY 14801 (607) 359-3436
1229 Lowman Road, Lowman, NY 14861 (607) 737-0281

SALES TAX AND DELIVERY CHARGE ADDED TO ABOVE COSTS.

2021 PRICE SHEET FOR FRESH WATER TANKS



Custom Mix Concrete, Inc.
Your Full Service Concrete Supplier

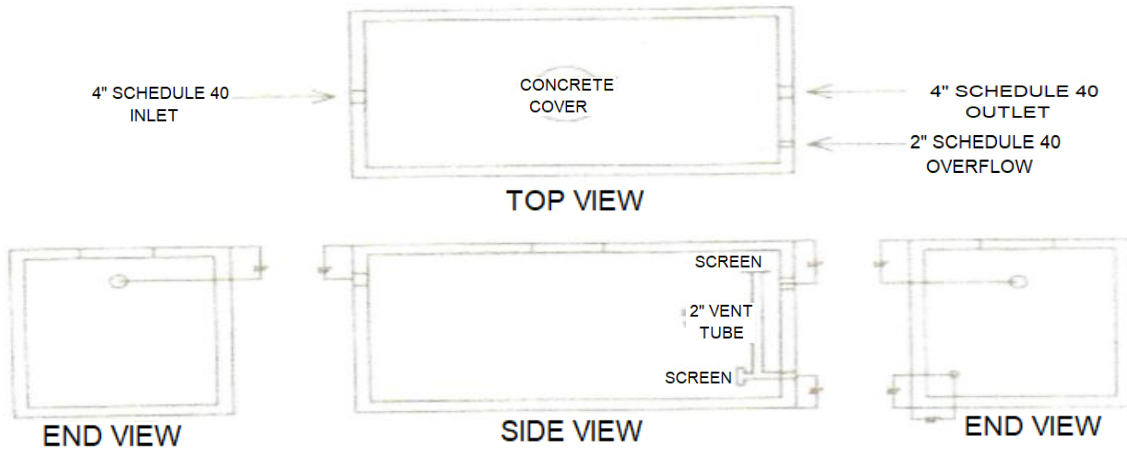

SHOWN: FRESH WATER TANK

DIMENSIONS

	<u>LENGTH</u>		<u>WIDTH</u>		<u>HEIGHT</u>		<u>WEIGHT</u>		<u>PRICE</u>
FRESH WATER TANK	96"	x	62"	x	68"		7,724 LBS.		\$ 810.00/EA.

SALES TAX AND DELIVERY CHARGE ADDED TO ABOVE COSTS.

*DELIVERY	HOURLY RATE
BOOM TRUCK	\$100.00 /HR.
TRACTOR TRAILER	\$125.00 /HR.

CONTACT INFORMATION:

President - John Pipher (607) 481-1222
 Sales Representative: Rick Hitchcock (607) 731-9248
 Block Shop Manager: Kelly Crane-Donley (607) 769-7833
 E-Mail: custommixconcrete@gmail.com

LOCATIONS:

206 W. Water St. Addison, NY 14801 (607) 359-3436
 1229 Lowman Road, Lowman, NY 14861 (607) 737-0281

*Delivery Starts at time of load to time truck gets back to our shop.

2021 PRICE SHEET FOR HEADWALLS



Custom Mix Concrete, Inc.
Your Full Service Concrete Supplier

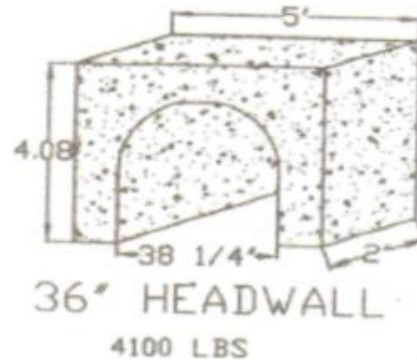
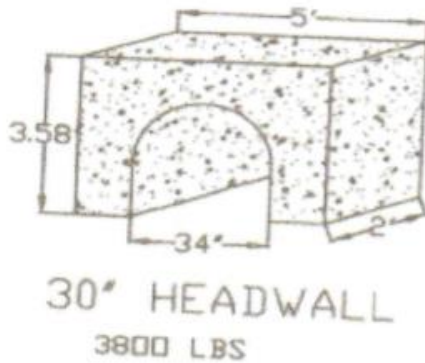
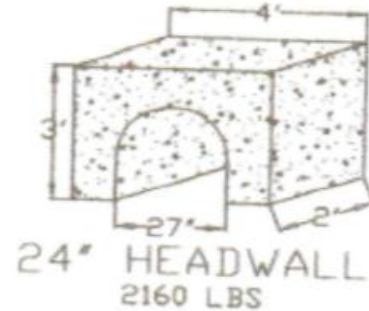
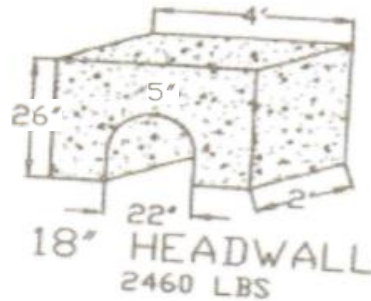
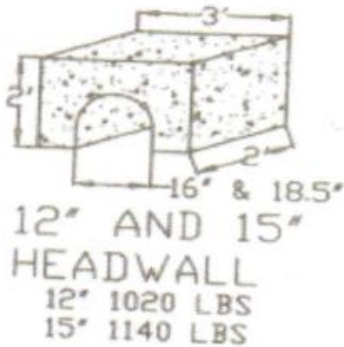

SHOWN: 12', 15", 18", 24", 30" & 36" HEADWALLS

4000 PSI CONCRETE WITH REINFORCED BARS. USED FOR PIPE CULVERTS

<u>DIMENSIONS</u>	<u>WEIGHT</u>	<u>PRICE</u>
FITS 12" OR 15" STORM PIPE	1,020 LBS. & 1,140 LBS.	\$ 160.00
FITS 18" STORM PIPE	2,160 LBS.	\$ 200.00
FITS 24" STORM PIPE	2,460 LBS.	\$ 220.00
FITS 30" STORM PIPE	3,800 LBS.	\$ 335.00
FITS 36" STORM PIPE	4,100 LBS.	\$ 405.00

SALES TAX AND DELIVERY CHARGE ADDED TO ABOVE COSTS.

<u>*DELIVERY</u>	<u>HOURLY RATE</u>
BOOM TRUCK	\$100.00 /HR.
TRACTOR TRAILER	\$125.00 /HR.

*Delivery Starts at time of load to time truck gets back to our shop.

CONTACT INFORMATION:

President - John Pipher (607) 481-1222

Sales Representative: Rick Hitchcock (607) 731-9248

Block Shop Manager: Kelly Crane-Donley (607) 769-7833

E-Mail: custommixconcrete@gmail.com

LOCATIONS:

206 W. Water St. Addison, NY 14801 (607) 359-3436

1229 Lowman Road, Lowman, NY 14861 (607) 737-0281

2021 PRICE SHEET FOR CATCH BASINS



Custom Mix Concrete, Inc.
Your Full Service Concrete Supplier

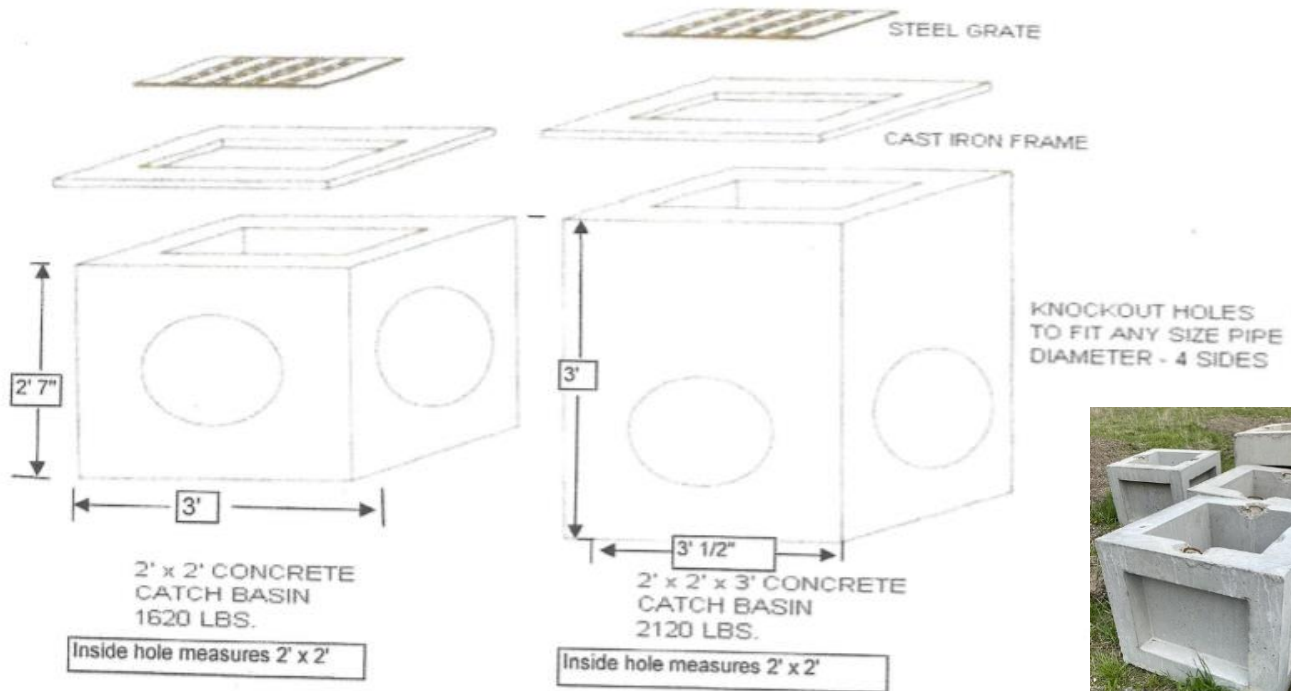

USED FOR STORM DRAINAGE APPLICATIONS, 2' x 2' OUTSIDE DIAMETER, 6" CONCRETE WALLS, 3500 PSI CONCRETE WITH REINFORCED BARS.

DIMENSIONS:

2' x 2' x 2' CONCRETE CATCH BASINS
INCLUDES STEEL FRAME & GRATE
CATCH BASIN ONLY
FRAME & GRATE ONLY

2' x 2' x 3' CONCRETE CATCH BASINS
INCLUDES STEEL FRAME & GRATE
CATCH BASIN ONLY
FRAME & GRATE ONLY

CATCH BASIN RISER \$20.00/EA.

SALES TAX AND DELIVERY CHARGE ADDED TO ABOVE COSTS.

*DELIVERY	HOURLY RATE
BOOM TRUCK	\$100.00 /HR.
TRACTOR TRAILER	\$125.00 /HR.

WEIGHT
1,620 LBS.

2,120 LBS.

PRICE
\$625.00/EA.

\$255.00/EA
\$390.00/EA

\$675.00/EA.

\$305.00/EA
\$390.00/EA

CONTACT INFORMATION:

President - John Pipher (607) 481-1222
Sales Representative: Rick Hitchcock (607) 731-9248
Block Shop Manager: Kelly Crane-Donley (607) 769-7833
E-Mail: custommixconcrete@gmail.com

LOCATIONS:

206 W. Water St. Addison, NY 14801 (607) 359-3436
1229 Lowman Road, Lowman, NY 14861 (607) 737-0281

*Delivery Starts at time of load to time truck gets back to our shop.

2021 PRICE SHEET FOR DRYWELL TANKS



Custom Mix Concrete, Inc.
Your Full Service Concrete Supplier

SHOWN: 500 GALLON CHAMBER TANK



500 GALLON CONCRETE DRYWELL CHAMBER:

DESCRIPTION	WEIGHT	HEIGHT	HEIGHT	HEIGHT	INTERIOR VOLUME	PRICE
					(GALLONS)	
500 GALLON	3,000 LBS.	34"	94"	60"	500	\$510.00

DRYWELL COVERS: (NOTE: DRYWELL COVERS HAVE 16" HOLE AND ARE 7 - 9" THICK)

5' DRYWELL COVER	\$115.00
6' DRYWELL COVER	\$125.00
8' DRYWELL COVER	\$175.00

SALES TAX AND DELIVERY CHARGE ADDED TO ABOVE COSTS.

*DELIVERY	HOURLY RATE
BOOM TRUCK	\$100.00 /HR.
TRACTOR TRAILER	\$125.00 /HR.

CONTACT INFORMATION:

President - John Pipher (607) 481-1222

Sales Representative: Rick Hitchcock (607) 731-9248

Block Shop Manager: Kelly Crane-Donley (607) 769-7833

E-Mail: custommixconcrete@gmail.com

LOCATIONS:

206 W. Water St. Addison, NY 14801 (607) 359-3436

1229 Lowman Road, Lowman, NY 14861 (607) 737-0281

*Delivery Starts at time of load to time truck gets back to our shop.

